



**Automatic controller  
staircase lighting  
Smart Stairway SS-26 LCD Pro**  
*User manual.*



[HTTP://XOPC.NET.UA](http://xopc.net.ua)  
+380 999 500 300  
E-MAIL: [SALE@XOPC.NET.UA](mailto:SALE@XOPC.NET.UA)

## 1. Introduction.

The controller is designed for automatic lighting of stairs using LED light sources with a current of up to 5A per channel. One controller is able to provide lighting from 4 to 26 steps.

## 2. Package.

The basic equipment.

- User guide. - 1 PC.
- automatic step lighting controller "Smart Stairway" - 1 pc.

## 3. Technical characteristics

1. Number of channels (number of steps)	Minimum - 4 The maximum is 26
2. Supply voltage	DC 12V / DC 24V.
3. Maximum load current for 1 channel (1 step)	5A (60W at 12V, 120W at 24V.)
4. Sensitive elements	Pyroelectric sensors (log. 1), ultrasonic rangefinders, IR sensors with logic zero, light level sensor.
5. Power supply of sensors of digital inputs:	DC5V
6. Degree of protection	Ip20
7. Ambient temperature	-5...+40° C
8. Dimensions of the controller body	139x89x65 mm
9. Power of the controller in standby mode (no more):	0.3W.
10. Controller power in load mode (no more):	3.5 W

## 4. The main advantages of the system.

1. Powerful output channels that control the load on each of the 26 channels up to 5A when the load supply voltage of the channels is DC12 or 24V. Accordingly, the maximum power per channel can reach 60W at 12V, or 120W at 24V. That is, you no longer need an amplifier, it is already built into the controller.
2. Convenient mounting on a DI N-rail in standard electrical installation built-in and external boxes.
3. Digital motion sensors in standard electrical installation boxes.
4. Support for ultrasonic distance meters. Convenient setting of the trigger distance. Constant indication of the current distance, which makes setting up and using this type of sensor quite convenient.
5. The controller supports sensors with a high signal at rest and zero when triggered. This is relevant for NPN infrared distance sensors on the reflected beam such as E18-D80NK, Sharp and others.
6. The remote light sensor allows you to choose a place of installation with a constant level of light independent of turning on or off the lighting of the stairs or additional light sources. After turning on the stairs, the sensor is not polled by the controller and the change in the level of illumination no longer affects the operation of the stairs until the end of the cycle of turning on/off the light of the stairs.
7. Convenient and intuitive system setup.
8. Adjustable "alternate illumination" of the first and last steps with brightness from 0 to 100%.
9. The possibility of changing the total brightness of the steps from 20% to 100% of the maximum brightness.
10. The possibility of connecting a through switch for lighting control at any time of the day, regardless of the lighting.
11. Low level of energy consumption.
12. Long service life of LED lighting sources (strips or spotlights).
13. Ease of installation and operation.

When motion is detected the backlight in the direction of human movement. Those, triggered by the sensor to the opposite. If in the process of moving when not fully backlight load sensor on the opposite side - is turned counter lights in the direction of movement of another person logged on to the ladder. After the staircase turns completely switched standby timer (specified in the Settings menu to claim 5), after which the backlight turns off smoothly stages in the same order. If any of the sensors are triggered during the timer countdown, the timer restarts and starts counting from the beginning.

If the "Up" button or the "Down" button is pressed in the standby mode (or the buttons are not locked to the "Up Button" "Down Button" inputs), the backlight of the ladder steps will turn in the direction from the pressed button to the opposite side. The light will be on until any of these buttons is pressed again.

**Using a light sensor.**

The controller can be used with or without a light sensor. When connecting the light sensor to the controller, its use should be activated (item 1. Settings) or deactivated if the sensor is not used. The sensor should be installed in such a place that it would not get light from the interior lighting. The digital sensor supplies a logical 0 to the controller port when the illumination is insufficient or a logical unit if the illumination level is greater than the set limit. In case of insufficient lighting the duty of the first and last steps is activated and the controller is allowed to include illumination of stairs on signals from motion sensors depending on the established algorithm (see above). If when moving up the stairs with the stairs on or off, the light suddenly gets on the light sensor brighter than the threshold of the controller - the lights of the stairs and the duty steps will be turned off, and the controller will go into standby mode. The operation of motion sensors and processing of human meters on the stairs is carried out even when the illumination on the signal of the light sensor is not carried out.

### 5. The controller control and connection elements.

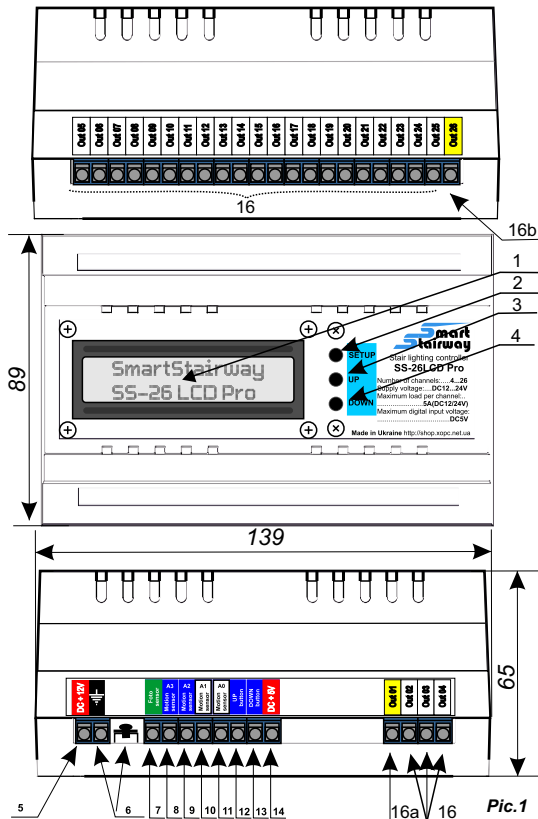

- 1-LCD display 16x2 with backlight. Displays the status of the controller and is used for system settings.
- 2 "SETUP" settings mode selection button
- 3 "Up" button. Turning on the steps from above in the working mode or increasing the parameter in the settings mode.
- 4 "Down" button. Enable steps from below in working mode or decrease the parameter in settings mode.
- 5 The external power supply is voltage stabilized. DC 12/24V.
- 6 Common input from the power supply unit "ground" (The negative terminals of the sensors and external 12/24V power supply are connected)
- 7- Signal wire of the light sensor. (Operating voltage  $\leq 5V$ )
- 8 - Digital TTL input of the lower sensor ("Trigger" for the ultrasonic sensor)
- 9 - Digital input "Echo" for the lower ultrasonic sensor
- 10 Digital TTL input of the upper sensor ("Trigger" for the ultrasonic sensor)
- 11 - Digital input "Echo" for the upper ultrasound sensor
- 12- Digital input of the upper switch (clock button). (Operating voltage  $\leq 5V$ )
- 13- Digital input of the lower switch (clock button). (Operating voltage  $\leq 5V$ )
- 14- DC +5V power output for connecting motion and light sensors
- 16- Controlled power outputs (DC-12V) for connecting stairs 1 ... 26.
- 16a, 16b - Exits 1.26 - alternate upper and lower steps.
- 17 - Indicator of software use of the light sensor. "On" - used, "Off." - not used. If the indicator is on, the backlight will turn on only when there is insufficient light. In all other cases, inclusion will be impossible. This mode is set in item 1 of the settings menu.

### 6. Scheme and how to connect.

1. Please read this user manual carefully before connecting the controller.
2. Check the availability of the necessary tool.
3. Before connecting the equipment, do a test installation to make sure system performance.
4. Choose a place to install the box for the controller (for example, under the stairs or indoors switchboard).
5. Install the box for the controller.
6. Install the controller on the DIN rail.
7. Install the stair lighting elements (LED strips or spot lights). At the same time, keep in mind that the load power per channel should not exceed 5A. You can also use spot LED lights based on 1-watt LEDs or other similar lights with 12W power ( 24V) of direct current. Please note that the next first and last steps are connected to connectors "Out 01" and "Out 26" regardless of the number of steps of your stairs. When installing LED strips on metal surfaces, pay special attention to the additional insulation of the metal surfaces, as the 2-sided adhesive tape that is available on the LED strip does not provide reliable insulation. Also, insulate the edges of the strip at the cut points with heat shrink tubing, since the strip often has twisted contacts during the cut months, which can also cause short circuit to a metal surface.
8. Route the cable (eg PV-3, AWG18-AWG23) from the steps to the controller installation location. At the same time, you can lay one common power supply wire and connect all stages to it in parallel. In this way, the number of wires can be reduced by 2 times. It is recommended to lay the wires in strobes or mounting boxes.
9. Connect the LED strips to the laid wires using special connectors. Or with the help of soldering. If recessed point LED lights are used - connect them according to the instructions on the lights.  
The positive wire of the lamps (+12) is connected to the common positive output of the controller (Fig. 1, item 15) or directly to the positive terminal of the power source. Connect the negative ("-") outputs to the corresponding outputs (Fig. 1, 16) of the controller. **WARNING!** A reverse polarity or short circuit of the digital outputs of the stage lighting control (16) will cause the channel, group of channels or the controller as a whole to fail.
10. Installation of motion sensors:  
10.1 Motion sensors must be installed at the beginning of the first and last steps.  
The distance horizontally from the sensor to the beginning of the step is about 5-10 cm, vertically - about 5-15 cm. (for an ultrasonic sensor, at least 40 cm in radius.)  
10.2 Route the cable to the motion sensors. It is recommended to use a shielded multi-core signal transmission cable with a cross-sectional area of at least 0.35 square mm. depending on the remoteness of the sensors from the controller, because extraneous electromagnetic guidance from possible high-voltage consumers and radio emitting equipment in the room can cause false operation of the sensors due to the occurrence of induction currents in the signal wire. Install the box (socket) in the wall. For ultrasonic sensors, the cable length should not exceed 8 meters, the screen should be grounded.



Wiring of the controller in the case of the use of one down ultrasonic rangefinders

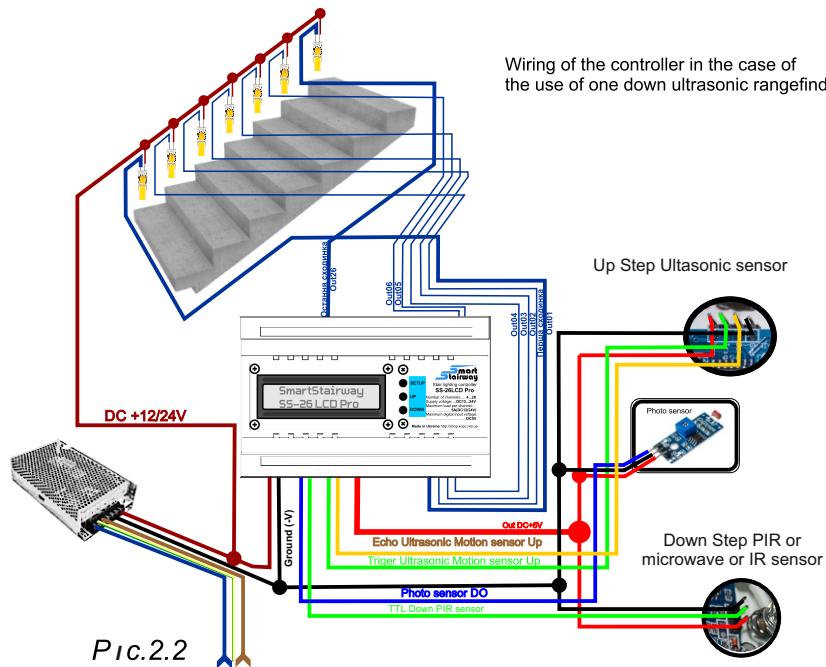

Pic.2.2

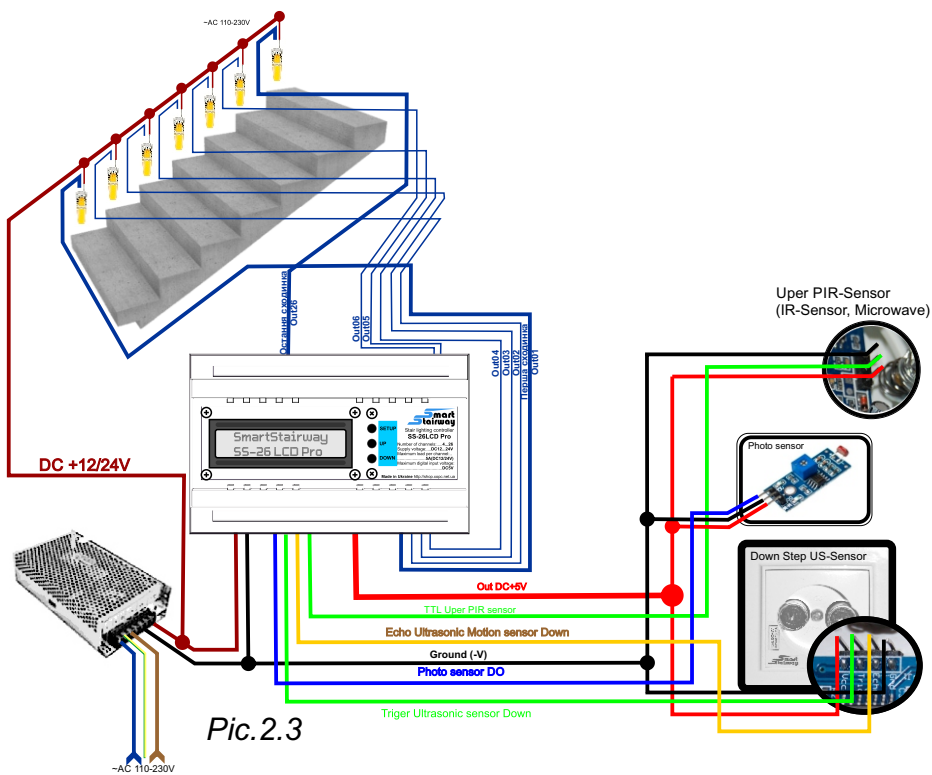

Pic.2.3



## 7. System settings

SETUP->1.  
Photo sensor: ON/OFF

SETUP->2.  
steps: 4...26

SETUP->3. Standby  
brightness: 0...255

SETUP->4. Switch-  
ing speed: 3...100

SETUP->5. Waiting  
time (sec.): 0...200

SETUP->6. Overall  
brightness: 0...200

SETUP->7. Sensor  
Up->PIR Dn->PIR

SETUP->7. Sensor  
Up->US Dn->PIR

SETUP->7. Sensor  
Up->PIR Dn->US

SETUP->7. Sensor  
Up->US Dn->US

SETUP->8. Sensor  
Up Distance: 5...120

SETUP->9. Sensor  
Dn Distance: 5...120

1. Selecting the setting menu items is done by pressing the "SETUP" button after you have passed all the settings menu items, the changes will be saved in the device's memory. If you do not complete all menu settings and turn off the power during setup, the change will not be saved. This setting menu item allows you to set whether the light level sensor will be used. Using the "Up", "Down" buttons. "ON" - the sensor will be used, "OFF" - the sensor is not used.
2. Set the number of steps. Use the "Up" and "Down" buttons to select the desired number.
3. Brightness of the first and last steps in the standby mode. By means of the "Up", "Down" buttons the brightness is required. If you want the first and last steps to be switched off in standby mode - set to 0.
4. Switching speed. The shutdown speed will be twice as fast.
5. Standby time before switching off the stair lighting. The time is counted after the last operation of any of the sensors.
6. The overall brightness of all steps in working mode. 0 - does not decrease, 200 - will be set to 20% of maximum brightness.
7. Select the type of sensors you use. Press the "Down" button until the desired value for the upper (UP) and lower (Dn) sensors is set on the display.
8. Setting the minimum distance to the obstacle for the upper ultrasonic sensor (centimeters). If the upper sensor is not ultrasonic - the menu item is not displayed.
9. Setting the minimum distance to the obstacle for the lower ultrasonic sensor (centimeters). If the lower sensor is not ultrasonic, the menu item is not displayed.

### Factory reset

Clause 6 of the setup menu provides an engineering function to reset the settings to those preset by the manufacturer. To do this, simultaneously press the "Down" + "Up" + "Setup" buttons and hold them until the second line on the display is filled with dots. Then immediately release the "Setup" button but keep pressing "Down" + "Up" until "Resetting.Wait" appears. then the settings will be reset. Reboot the system.

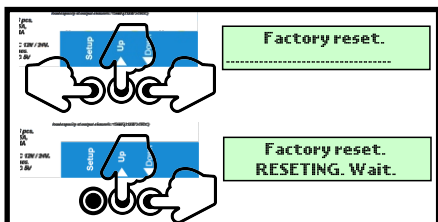

## Information on the display during operation.

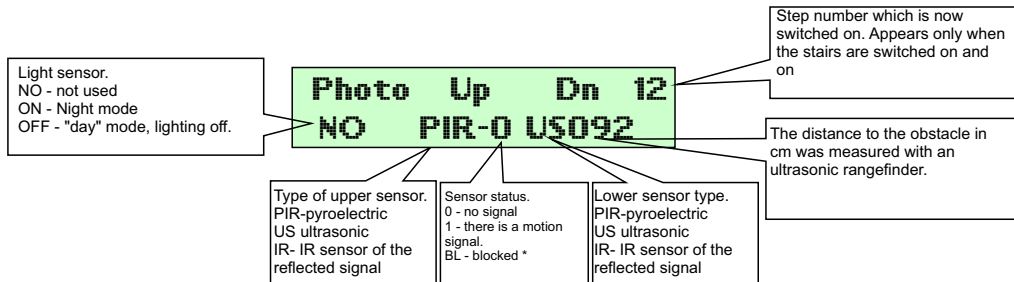

<p>Photo Up Dn OFF -----</p>
----------------------------------

When the light level in the room is higher than set - the light sensor does not allow the system to turn on. Instead of measuring sensor values, you see dashes.

<p>Photo Up Dn 12 NO PIR-BL US092</p>
---

\* If a pyroelectric sensor is used, the sensor is locked for 90 seconds after the first power-up to avoid erroneous switch-ons during sensor warm-up. The display shows the status BL when a high signal appears at the input (logical unit)

The display illumination is only switched on when the controller switches to the ladder switching mode or when you have pressed the "SETUP" button and entered the settings either "Up" or "Down" and forcibly switched on the lighting. "Button pressed" will be displayed.

## Features of ultrasonic rangefinders

Ultrasonic rangefinders have certain technological shortcomings. They have a delay of ultrasonic signal processing for 50 milliseconds, and a delay of 0.5 seconds in the absence of reflected sound. Ultrasonic sensors cannot detect an obstacle if the obstacle has sound-absorbing coatings. The use of ultrasonic rangefinders is justified, unless the stairs have a fence and behind the stairs there is a passage area without people coming out of the stairs, the movement of which can cause the system to work. If it is possible to install pyroelectric sensors, it is better to choose them. The distance to the barrier is programmatically limited to no more than 120 cm. At higher values, the sensor will not measure distance. This reduces the time of distance measurement by the system and avoids significant delays in operation.

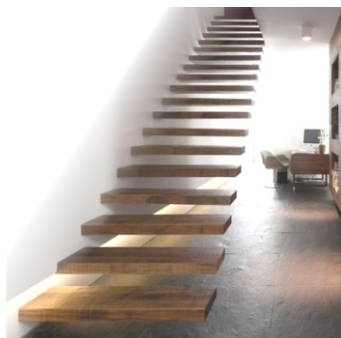

On the page with the description of the ultrasonic sensor you can see the diagram of angles of measurement of distance in the vertical and horizontal planes. Looking at it, it is clear that sound waves propagate at an angle of about 60 degrees in the vertical plane. Therefore, it is especially important to keep a minimum distance from the floor or step of at least 50 cm, and any other surfaces in the horizontal plane. Otherwise, the sensor will measure the distance to the horizontal plane (floor or steps) and not to the obstacle on the stairs. Accordingly, the ladder will be switched on at all times and entry into the settings menu will not be possible until the ultrasonic rangefinder is switched off.

Setting the minimum distance to the obstacle is performed in items 8 and 9 of the settings menu. If the distance to the obstacle is less than the value stored in the memory of the controller - the controller turns on the lights. When the lights are on, the fault menu will not be accessible.



## 8. Possible malfunctions and ways of their elimination

Troubleshooting	elimination method
does not light up the red LED "power" when power up	Check the power supply Check unit polarity feeding
Some steps do not light up	Check the LED strips.  check polarity LED strips.
spontaneous drawdown sensors (Stage times lit independently even if there is no motion sensors before or is lit constantly)	Less effective range Sensors regulators "sensor 1" and (or) "Sensor 2"  remove foreign objects Actions range from sensors  check whether the sensors Fresnel lens soiled.
the system goes into "night" mode, even if indoor lighting has not changed (For example, passing the sensor illumination)	check whether the sensor is overshadowed illumination  adjust the light level sensor switching using the trimmer located on the light sensor.
other system problems	contact the manufacturer's customer support.

## 9. Operating and safety rules.

1. The system is designed for operation in dry and clean rooms. Not allowed outdoor use or wet rooms.
2. The system must not be used near flammable liquids, gases, vapors, explosive or liquid chemical species.
3. Before connecting power to the system carefully check whether all items in this manual respected.
4. If during the installation or operation of the system detected damage to the elements Turn off the power and remove the shortcomings.
5. Installation of the system requires certain skills and knowledge of electrical fundamentals. Necessary control instrumentation and systems installation mounting instrumenty. Dovert professional electrician.

## 10. Additional information

1. Sources of illumination as LED light sources may be:
  - LED Strip full-length stage (no more 4,8Vt);
  - Segments LED strips;
  - Spotlights mounted on the walls along the staircase steps or stair risers;
  - A combination of ribbons and spotlights (total capacity of not more than 4.8 W / step).
 Mount LED strips can be carried out:
  - In special aluminum profiles with a diffusing screen;
  - On plastic brackets (in this case it is better to use a waterproof LED strip).
  - For easy connectivity combined minus and plus contacts LED light sources use a single-pole terminal blocks or screwless terminals.
3. Power Supply
  - Sit in the power supply, based on the required power of the system with a 30% margin (at least 10%);
  - Connect the power supply through a circuit breaker to de-energize the system quickly if necessary;
  - Use the overvoltage protection device - it will protect your system in the event of unexpected power surges.
  - If you use multiple series-connected controllers with different power supplies, the minusovyeprovoda should be combined to connect lighting.

# Additional Information

## The order of connecting LED strips or luminaires.

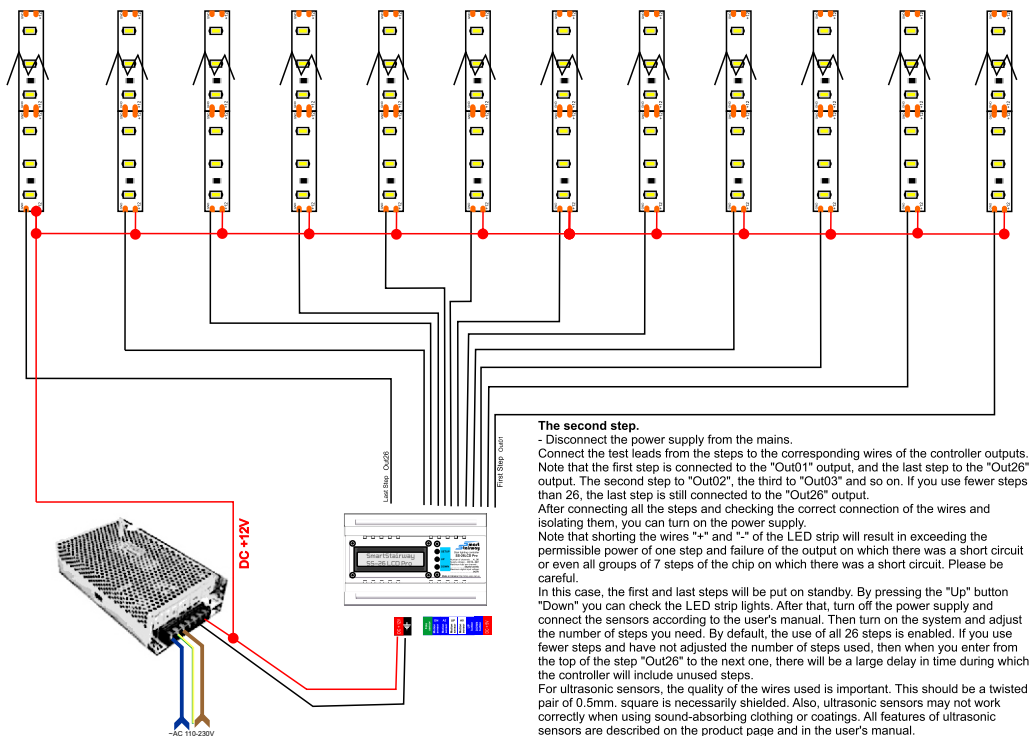
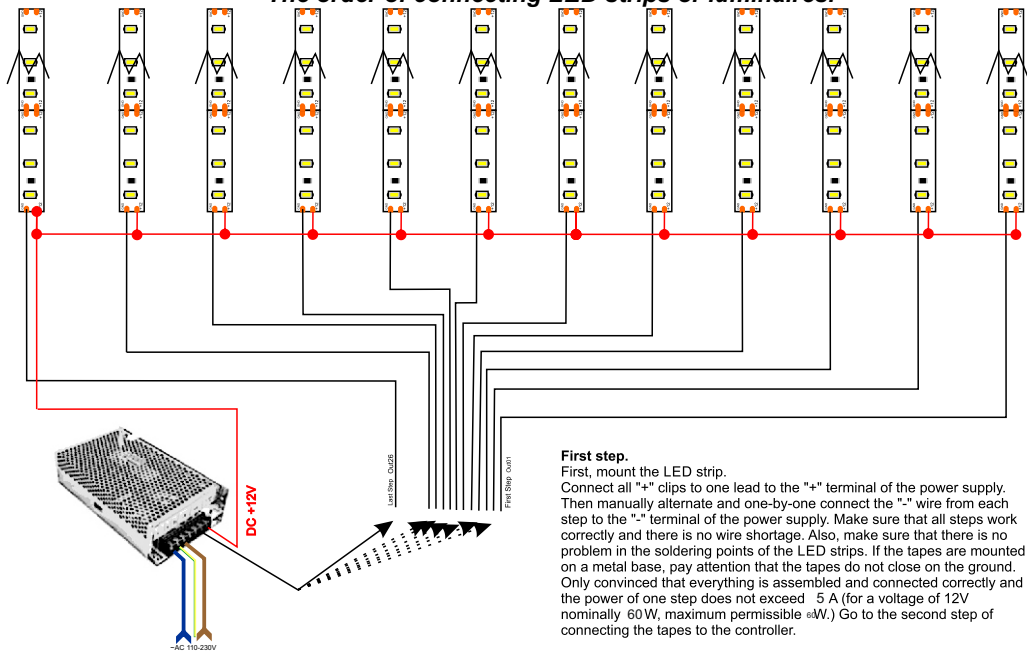

# Ultrasonic rangefinder sensor lock Smart Stairway US-SR042

This sensor may not be included in your kit. Depending on what kit you purchased.



The sensor can be used with the backlight controller Smart Stairway steps or security systems which is used to power the sensor voltage from 5V DC with TTL logic levels 5V. The sensor is designed for installation in mortise box rosette diameter of 65 mm.

### Main Features:

- Static Current: Less than 2mA
- Output Signal: Electric frequency signal, high level 5V, low level 0V
- Sensor Angle: Not more than 15 degrees
- Detection Distance: 2cm-120cm
- High Precision: Up to 0.3cm
- Input Trigger Signal: 10us TTL impulse
- Echo Signal: Output TTL PWL signal

### The procedure for installing and connecting the sensor.

1. Install the sensor into the mounting hole with a diameter of 60 mm and a depth of at least 22 mm.
2. Ensure that power to the controller or alarm system is turned off.
3. Connect the wires to the sensor using a special connector or using soldering or connecting clamps if the the sensor module has a soldered wire. (Depending on the type of sensor). Follow the diagram in Figure 2 and colored marking wires (Figure 2). A **WARNING!** Incorrect wiring can cause the sensor and controller to fail!
4. Check the connecting wires.
5. Test and verify the sensor is correct.

Ultrasonic sensors are capable of detecting a distance in the range from 4 to 400 centimeters. The controller has a measurement range from 4 to 120 cm. Since ultrasound sensors work with a reflected sound signal. they cannot work properly with sound-absorbing surfaces and materials. Also, if the distance exceeds 1.2 meters, there may be a delay in operation due to the absence of a reflected sound signal. Consider this when choosing this type of sensor.

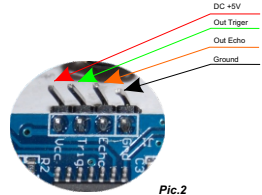

Pic.2

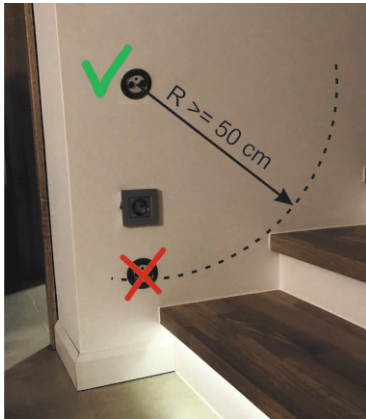

When choosing a place for installing the sensor, please observe a minimum distance to the nearest surface of at least 50 cm. Otherwise, the reflected sound signal can make the system impossible to work and will constantly cause the system to turn on. For connection, use a 4-core shielded wire no longer than 10m. The shield of the wire must be grounded.

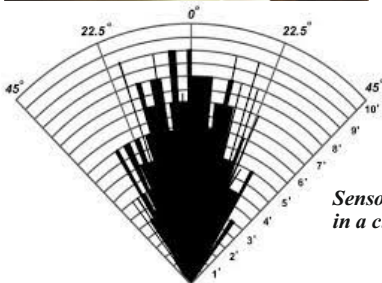
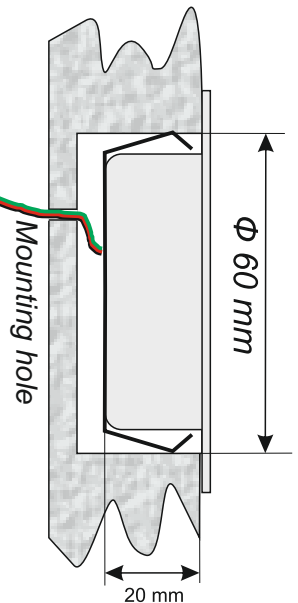

Sensor sensitivity diagram in a circular field.

This sensor may not be included in your kit.  
Depending on what kit you purchased.

## Pyroelectric motion sensor Smart Stairway PIR-SR501-1ELBI



Pyroelectric motion sensor is designed for use with digital receivers TTL, a logical unit when motion is detected. The sensor can be used with the backlight controller Smart Stairway steps or security systems which is used to power the sensor voltage from 5 to 20V DC with TTL logic levels of + 3.3V. The sensor is designed for installation in mortise box rosette diameter of 65 mm.

The main parameters Module HC-SR501	
parameter	Value
Value	3.2MM X 24MM X 18MM
Voltage	DC 4.5V- 20V
Current at OUT	<60uA
Output voltage	High and low level 3.3V TTL
Distance detection	2 - 5m (customizable)
Angle of detection	do 120 °
Pulse the detection of	5 - 200sek. (Customizable)
Time Lock	2.5sek the next measurement.
Operating temperature -20 + 80 ° C	-20 + 80 ° C
Mode	L - single capture, H - repeatable measurements

### Installation instructions.

1. Prepare the back box in the wall.
2. Connect the wires according to the marking on the sensor. (red - DC power +5 ... + 14V, black - ground, green - data.)
3. Install the PIR-SR501-1 ELBI pyroelectric sensor into the junction box.
4. Tighten the fastening screws lightly. (see fig. 1)
5. Install decorative covers 4. (see fig. 1)

### Setting up the sensor.

*These settings are optional. The sensor is supplied already configured and does not require configuration. Described settings should be made only if the default settings do not suit you. Through these settings you can degrade system performance. To carry out this work should be interpreted in that case if you have a certain knowledge and skills.*

1. Remove the sensor module housing 2 with a cover 3 of the mounting frame 1 (See. Figure 1) To do this, release the latch on the frame 1 (be careful not to break the latch).
2. Release latch 3 cover (be careful not to break the latch).. Remove the cover from the housing 2 (see. Figure 1)
3. To make the sensor settings by adjusting the trimmers according to Fig.2.
4. Replace the cover 3 back into the housing 2.
5. Install the body of the sensor with the sensor module and the cover assembly back into the mounting frame 1.

Make a sensor installed in the mounting hole according to the installation guide.

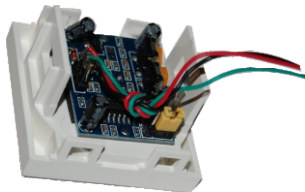
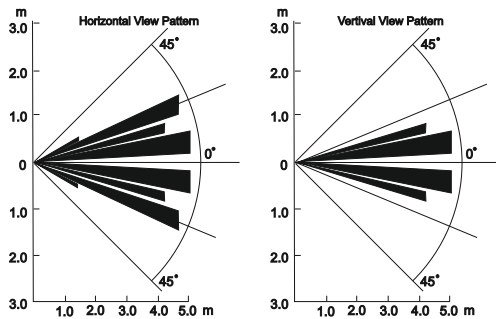

Figure 3

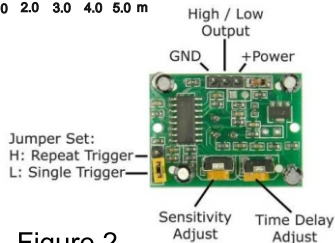

Figure 2



Figure 1

- 1 - Mounting Frame
- 2 - The body of the sensor with Fresnel lens.
- 3 - Protective cover pyroelectric sensor.
- 4 - laths.
- 5 - Sensor Module

Pyroelectric sensors require a warm-up time after switching on.

Within 30-90 seconds, several arbitrary inclusions of the light of the steps are possible. To avoid this, the SmartStairway system provides for locking the system for 90 seconds after switching on, if the system is configured to use pyroelectric sensors. During this time, the operation of the digital inputs of the pyroelectric sensors is blocked. In this case, the indication of the signal from the sensors is carried out only by the green and blue LEDs inside the case on the right side of the controller. This is normal and not a defect.

## Light sensor with digital output with the ability to adjust the sensitivity of triggering.

Light sensor used to detect light in the range of the sensor. The sensor can be connected via digital output to the microcontroller, or directly to the relays without microcontroller. As svitluchutyveho resistor element used MLG5516B.

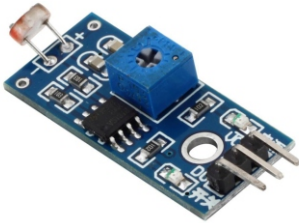

### Specifications:

- Operating voltage: 3.5 V-5 V;
- Digital output: 0 or 1;
- Fixed bolt hole for M3
- Size 53.1 x 11.3 x 13.8 mm
- Current: 15 mA;
- Adjustable sensitivity sensor;

Description of structural elements and instructions for installation and pidkyuchennya.

- 1 - svitluchutyvevy element MLG5516B
- 2 - Adjustable rezystor stvitlochutlyvosti.
- 3 - indicator light
- 4 - Power Indicator
- 5 - Signal digital output
- 6 - GND "Earth" ( "-" power supply)
- 7 - Power DC + 3,5 ... 5V

The sensor should be installed in such a way that svitluchutyvevy only common element falling light, the level of which should be measured.

Sensor connection is made to the stabilized direct current voltage source of 3.5 - 5V. Terminal 7 is connected to the positive vihodu controller or power source with the appropriate voltage.

Terminal 6 is connected to a general release of "land" or "-". Signal output 5 (D0) pidkyuchaetsya the corresponding output controllers or relays. After the power supply of the sensor light turns on 4. In case of insufficient light sensor turns off the indicator digital output 3. 5 podaetsya logical unit or zero, according to state lighting. The high level signal indicates the presence of light, low - about vidsutnist. Vidpovidno to vikorystanoho control device or controller will relay the signal to perform the action.

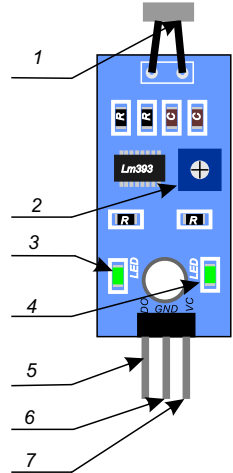

## Infrared distance sensor E18-D80NK



### Specification:

- Model: E18-D80NK
- Type: NPN / NO
- Power supply: 5 V
- Current strength: 30 mA if there are no obstacles, 45 mA if there is.
- Dimensions of the sensor body: 50x18 mm
- Distance: 5-80 cm (adjustable)
- Contacts: black - signal; brown +5 V; blue "-" common
- the angle of view is about 10 degrees.

The distance is 5 - 80 cm (it can be adjusted with an adjustable resistor on the back of the sensor), the output signal is digital binary, signals whether there is an obstacle in the field of view. 5V power supply.

Contains a transmitter and receiver in the infrared range. When triggered (if there is an obstacle in the field of view), the output voltage becomes equal to "0". In the absence of an obstacle - a logical unit

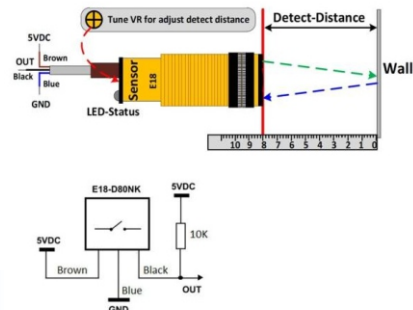

## Frequently Asked Questions

### **- Can I use a system with a 5V DC power supply?**

The system is designed to operate with a supply voltage of 8 to 25V DC. Working with power supplies and luminaires with a voltage different from the specified can cause damage or not stable operation of the system.

### **- Can I use DC12 or DC24V charging inverter as a power source?**

Not. The inverter is not a stabilized power supply and is not intended to power electronic devices. The inverter has an unstable output. Please use only 12 or 24V DC voltage stabilized power supplies depending on your LED strips or luminaires.

### **- What kind of lamps can I use?**

The system is designed to be used in conjunction with LED lights or LED stripes with a voltage of 12 or 24 VDC.

The current of the luminaires or LED strips should not exceed 0.4A (0.5A maximum, taking into account the resistance of the wires at the point of connection to the controller) for one step.

Exceeding the current will lead to system failure. So for one step, the maximum power of luminaires with a supply voltage of 12V DC is  $12V * 0.4A = 4.8W$ ;

with a supply voltage of 24V DC  $24V * 0.4A = 9.6W$ .

### **- What kind of power supply should I choose?**

The power supply should be selected based on the number of steps and the power of the luminaires of each step.

For example, you want to use 19 steps and install 4W lamps on each step:

$19 \text{ steps} * 4W = 76W$ . To the received capacity it is necessary to add 15% of the stock:  $76W + 15\% = 87.4W$ . You should choose a power supply with a power of at least 87.4W. The nearest larger of the available 90W or more.

The voltage of the power source should be the same as that of your luminaires (12 or 24 VDC).

### **- Can I use the system from the outside?**

The system does not have water protection (IP20) and is designed for indoor operation.

The humidity in the controller or sensors "Smart Stairway" is not permissible.

You must ensure that it is protected against water when used outdoors. When using LED stripes from outside the room, you must reliably protect the system and the wiring from water ingress.

### **- I've connected everything, but I have some steps that shine less brightly than others and some do not turn on or off. What happened?**

I can say with certainty that during the connection you made the closure of the wires of the LED strips or used LED stripes of too high power. This caused the failure of the controller output chips. Now they should be replaced. Also, sometimes the closure occurs when the LED strips come in contact with metal steps or aluminum profiles in which LED stripes are installed. To avoid this it is necessary to check the operation of each individual step before connecting to the controller. Also, the closure can occur when wet cleaning on the stairs and water on the LED strip without moisture protection. What can also cause a system closure and system outage. If you wash the ladder, please turn off the power to the system and turn it on again only after the staircase has dried completely.

### **- I've connected everything and everything works for me, but I have a big delay between switching on / off the last and the penultimate steps.**

By default, the system is supplied configured to use 26 steps. If you use fewer steps, the system still spends time turning on and off unused steps. Therefore, you see a delay. You need to configure the system for the number of steps that you use. To do this, enter the menu item No. 2 and press the "Down" button until the penultimate step is turned off. Then click the "Up" button once. In this case, all your steps will be included. Press the SETUP button until the red LED is turned on continuously. Setup is complete.

### **- Can I turn on the system so that all the steps are turned on until I turn them off?**

Yes, there is such an opportunity. When you press the Up button or the Down button, the steps are turned in the direction of the pressed button and will be turned on until you press either of the two buttons again. Also you can connect a button without a latch (buttons for a door bell for example) to the inputs "Up button" and "Down button". In this case, one wire from the button should be connected to the output "+ 5V", and the second wire to the input "Up button" or "Button down".